

MAX-303 Xenon Light Source 300W Technical Information



MAX-303

UV (250-385nm) Light Guide (Quartz)

*Please regard the following data as a reference.

Measuring Condition

Sensitivity of Detector

Wavelength (nm)	S254	S365
200	0	0
250	100	0
300	0	0
350	0	100
400	0	0

Detector
 A. Accumulated UV Power Meter UIT-150 S254 (Ushio)
 B. Accumulated UV Power Meter UIT-150 S365 (Ushio)
 C. Power Meter MODEL2835C (Newport)

Quartz Light Guide
 φ5mmx1m

Xenon Light Source MAX-303
 · UV Lamp
 · UV Mirror Module

Spectral Distribution

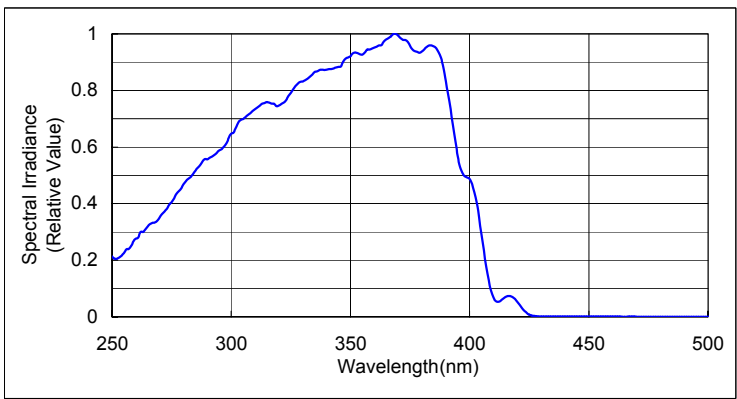

This graph shows the spectral distribution of MAX-303 with UV Lamp and UV Mirror Module measured by fiber spectrometer.

Illuminated Area & Center Illuminance at Different Distance

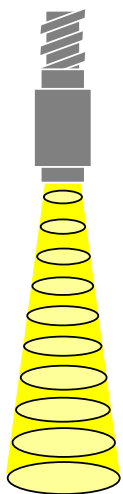

Distance	Detector Filter	Irradiance(mW/cm ²)		Irradiance(mW/cm ²)		
		A	B	C		
	Illuminated area	---	---	XHQA254	XHQA320	XHQA380
10mm	φ9mm	664.00	1699.00	---	---	---
20mm	φ13mm	309.00	700.00	---	---	---
30mm	φ18mm	160.00	342.00	9.10	33.90	36.70
40mm	φ24mm	95.50	196.00	6.74	24.90	27.10
50mm	φ30mm	63.10	128.00	4.91	18.20	20.00
60mm	φ35mm	44.60	90.10	3.75	13.60	15.10
70mm	φ40mm	32.60	65.40	2.89	10.50	11.70
80mm	φ45mm	25.10	50.10	2.30	8.37	9.34
90mm	φ50mm	19.70	39.60	1.87	6.82	7.64
100mm	φ53mm	16.00	32.10	1.54	5.60	6.29

Reference for XHQA (Bandpass Filter)
http://www.asahi-spectra.com/opticalfilters/bandpass_filter.html

MAX-303

UV (250-385nm) **Light Guide (Quartz)** **Collimator Lens (x 1.0)**

*Please regard the following data as a reference.

Measuring Condition

Sensitivity of Detector

Relative Spectral Sensivity vs Wavelength (nm)

Legend: S254 (blue), S365 (red)

Irradiation Distance

Collimator Lens x 1.0 Quartz Light Guide φ5mmx1m

Detector

A. Accumulated UV Power Meter UIT-150 S254 (Ushio)
 B. Accumulated UV Power Meter UIT-150 S365 (Ushio)
 C. Power Meter MODEL2835C (Newport)

Xenon Light Source MAX-303

- UV Lamp
- UV Mirror Module

Spectral Distribution

Spectral Irradiance (Relative Value) vs Wavelength (nm)

This graph shows the spectral distribution of MAX-303 with UV Lamp and UV Mirror Module measured by fiber spectrometer.

Illuminated Area & Center Illuminance at Different Distance

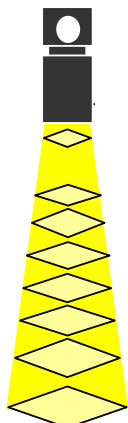

Distance	Detector Filter Illuminated area	Irradiance(mW/cm ²)		Irradiance(mW/cm ²)		
		A	B	C	C	C
		---	---	XHQA254	XHQA320	XHQA380
80mm	21 x 21mm	35.10	73.00	2.13	7.92	8.99
100mm	26 x 26mm	24.00	49.50	1.49	5.44	6.21
200mm	48 x 48mm	6.83	13.80	0.48	1.65	1.88
300mm	71 x 71mm	3.16	6.42	0.23	0.78	0.90
400mm	93 x 93mm	1.82	3.69	0.13	0.46	0.53
500mm	116 x 116mm	1.19	2.42	0.09	0.30	0.35
600mm	140 x 140mm	0.83	1.69	0.06	0.21	0.24
1000mm	230 x 230mm	0.29	0.59	0.02	0.08	0.09

Reference for XHQA (Bandpass Filter)
http://www.asahi-spectra.com/opticalfilters/bandpass_filter.html

MAX-303

VIS (385-740nm) Light Guide (Quartz)

*Please regard the following data as a reference.

Measuring Condition

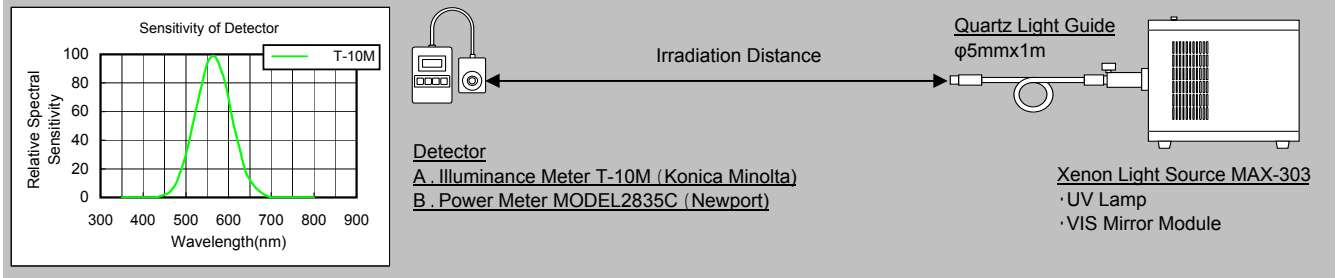

Spectral Distribution

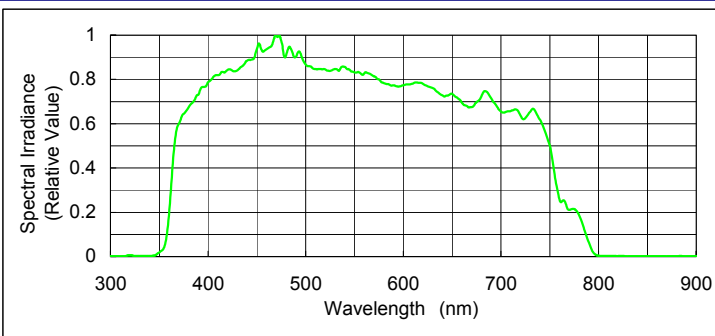

This graph shows the spectral distribution of MAX-303 with UV Lamp and VIS Mirror Module measured by fiber spectrometer.

Illuminated Area & Center Illuminance at Different Distance

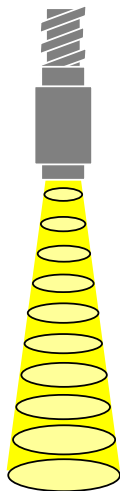

		Center Illuminance(lx)	Irradiance(mW/cm ²)		
Detector		A	B		
Distance	Filter Illuminated area	---	XBPA400	XBPA550	XBPA700
		10mm	φ9mm	10,253,000	---
20mm	φ13mm	6,897,000	---	---	---
30mm	φ18mm	4,474,000	40.00	51.80	41.00
40mm	φ24mm	2,983,000	27.80	36.30	28.90
50mm	φ30mm	2,051,000	19.50	25.50	20.30
60mm	φ35mm	1,491,000	14.40	18.90	15.10
70mm	φ40mm	1,137,000	10.90	14.30	11.40
80mm	φ45mm	895,000	8.55	11.30	9.02
90mm	φ50mm	713,000	6.93	9.12	7.28
100mm	φ53mm	583,000	5.79	7.63	6.11

Reference for XBPA (Bandpass Filter)
http://www.asahi-spectra.com/opticalfilters/bandpass_filter.html

Uniformity of Irradiation

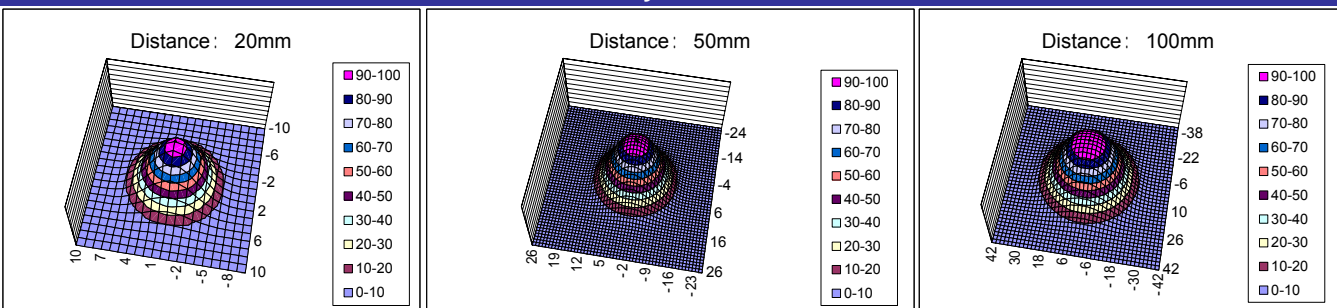

MAX-303

VIS
(385-740nm)

Light Guide
(Quartz)

Collimator Lens
(x 1.0)

*Please regard the following data as a reference.

Measuring Condition

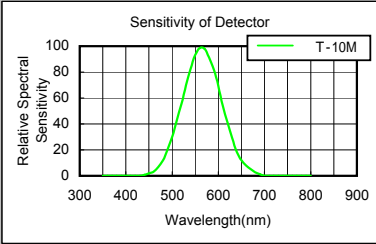

Detector
A. Illuminance Meter T-10M (Konica Minolta)
B. Power Meter MODEL2835C (Newport)

Collimator Lens x 1.0
Quartz Light Guide φ5mmx1m

Xenon Light Source MAX-303
·UV Lamp
·VIS Mirror Module

Irradiation Distance

Spectral Distribution

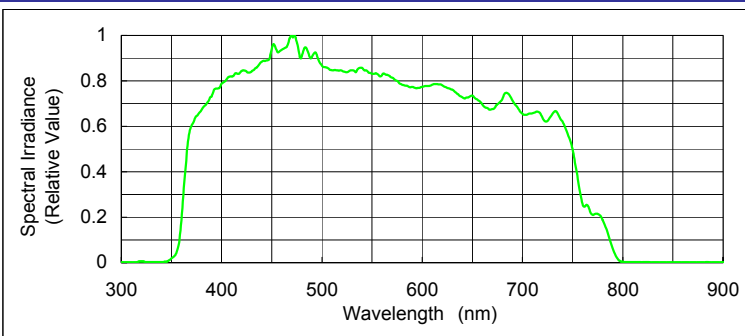

This graph shows the spectral distribution of MAX-303 with UV Lamp and VIS Mirror Module measured by fiber spectrometer.

Illuminated Area & Center Illuminance at Different Distance

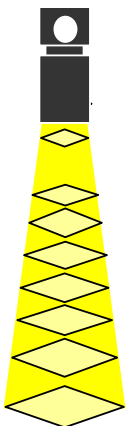

Distance	Detector Filter Illuminated area	Center Illuminance(lx)	Irradiance(mW/cm ²)		
		A	B		
		---	XBPA400	XBPA550	XBPA700
80mm	21 x 21mm	1,318,000	12.70	16.40	13.70
100mm	26 x 26mm	898,000	8.79	11.30	9.56
200mm	48 x 48mm	265,000	2.56	3.30	2.77
300mm	71 x 71mm	122,400	1.20	1.55	1.29
400mm	93 x 93mm	70,800	0.69	0.89	0.74
500mm	116 x 116mm	46,200	0.45	0.58	0.48
600mm	140 x 140mm	32,100	0.31	0.40	0.33
1000mm	230 x 230mm	11,700	0.11	0.15	0.12

Reference for XBPA (Bandpass Filter)

http://www.asahi-spectra.com/opticalfilters/bandpass_filter.html

Uniformity of Irradiation

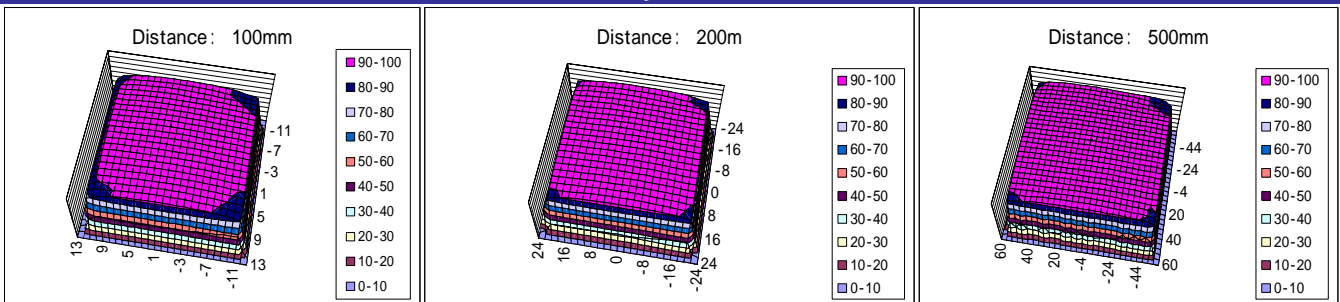

Comparison of Spectrum

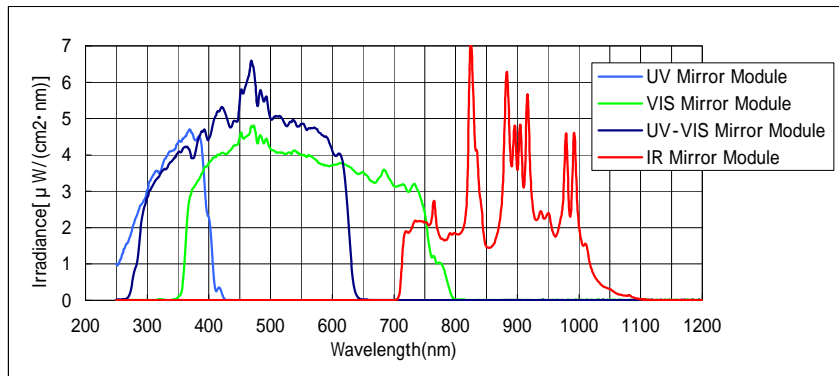

Note:
Irradiated Area: 400 x 400mm

Lamp Start-Up Characteristics

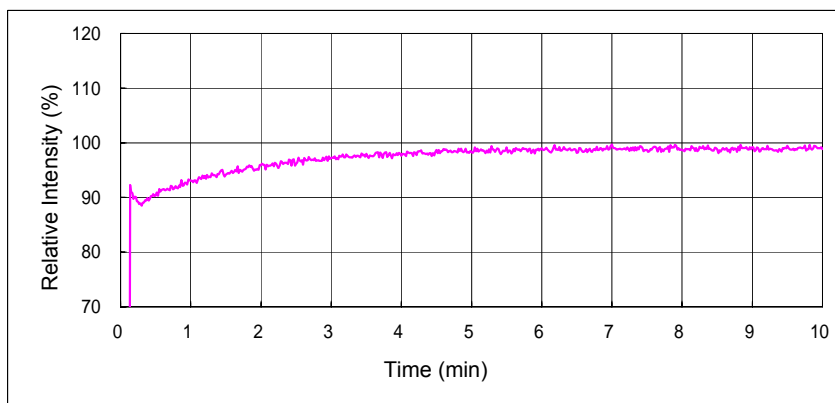

Lamp Fluctuation

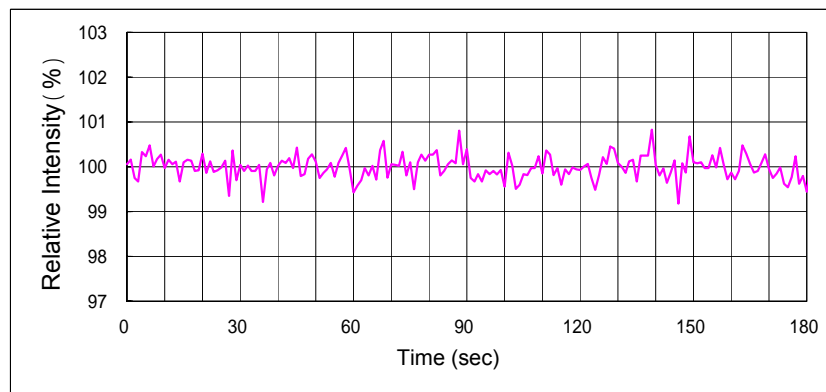

Note:
After 2 hours of turning on.
The data was obtained with regulated power supply.

Lamp Life

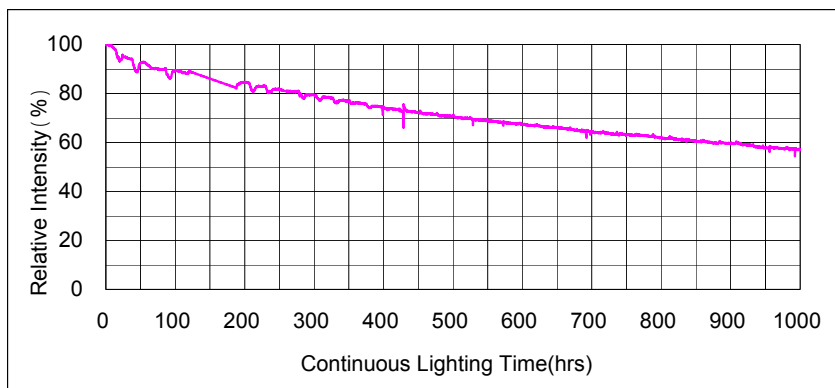

*We accept no responsibility for any errors or omissions, and we reserve the right to modify design, characteristics and products at any time without obligation.

ASAHI SPECTRA^{USA}
23505 Crenshaw Blvd., Suite 229 Torrance, CA 90505 USA
Email : info@asahi-spectra.com

www.asahi-spectra.com